

Model X19J

COMPACT CRAWLERS



MORE ECONOMIC

- Minimal emissions and noise pollution.

MORE PRODUCTIVE

- Reduce your set-up time with auto-levelling outriggers.

MORE ACCESS

- Equipped with track drive for easy manoeuvrability in sensitive environments.

SMART DESIGN

- Low weight for ease of transportation and operation in weight restricted areas.



Standard Features

- 0.69 m x 1.34 m Aluminium 2 person platform
- Slide bar rear entry
- Footswitch
- Full proportional control
- Articulating jib
- Powered platform rotator (124°)
- Remote Control (via cable to platform)
- Multi-lingual LCD display on platform console
- Platform console position sensor and lock
- Envelope management load sensing system
- Platform designed for ease of removal/changeover
- AC Cable to platform
- 6,5 mm (1/4 ") air/water line to platform
- Engine protection
- Automatic Stabilization
- Rubber Outrigger Pads
- Cylinder Rod Protection on Outriggers
- Automatic cut-out when out of level
- Powered track extensions/retraction
- 360° non continuous rotation
- Turntable alignment sensor and gauge
- Three emergency descent systems
- Electro-hydraulic controls
- Lifting/Tie down points

Standard Specifications

- | | |
|--------------------------------|--|
| Power Source | |
| • Engine Honda iGX440 | 11 kw Petrol |
| • AC electric motor 220V, 50Hz | 2.2kW |
| Tires | |
| • Standard | 1.24 m x 0.18 m x 0.30 m
Low Profile Non Mark Rubber Tracks |

Accessories & Options

- 0.59 m x 0.79 m Aluminium 1 person platform
- Hatz IB40 - 7.5 kW (10HP) Diesel Engine
- 110V, 50Hz single phase power system
- 100Ah/ 48V Electric engine with Lithium battery package incl. battery charger ¹
- 1.24 m x 0.18 m x 0.30 m Low Profile Black Rubber Tracks
- 2nd drive speed
- Special paint colour

¹ Replaces both combustion and electric engines

Model X19J

COMPACT CRAWLERS

Performance

- Working Height 18.67 m
- Working Outreach (Std Platform w 120kg) 6.55m
- Working Outreach (Std Platform w 200kg) 4.95m
- Up & Over Height w 120 kg 7.66 m
- Swing (non continuous) 360°
- Jib - overall length 1.43 m
- Jib - range of articulation (+/-) 83° (+0° / -83°)
- Platform size (standard 2 persons) 0.69 m x 1.34 m
- Stowed width (with std. 2P platform) 1.48 m
- Dimensions:
 - A. Stowed width (without platform) ¹ 0.79 m
 - B. Stowed height (on tracks) ¹ 1.98 m
 - C. Stowed length (on tracks) 4.47 m
 - D. Outrigger footprint 2.89 m x 2.88 m
- Machine weight (with standard platform) ² 2,080 kg
- Max. ground bearing pressure (on outriggers) 1.94 kg/cm²
- Max. drive speed (single speed m/c) Petrol 1.7 Km/h
- Gradeability 38%
- Maximum operating slope 11°
- Max. Approach / Depart angles Front 21° / Rear 21°
- Width of Undercarriage (Retracted/Extended) 0.79 m / 1.09 m

¹ With outrigger pads removed. Pads increase width by 196 mm and height by 120 mm in stowed position.

² Dry weight. Certain options or country standards may increase weight and/or dimensions.



Reach Diagram

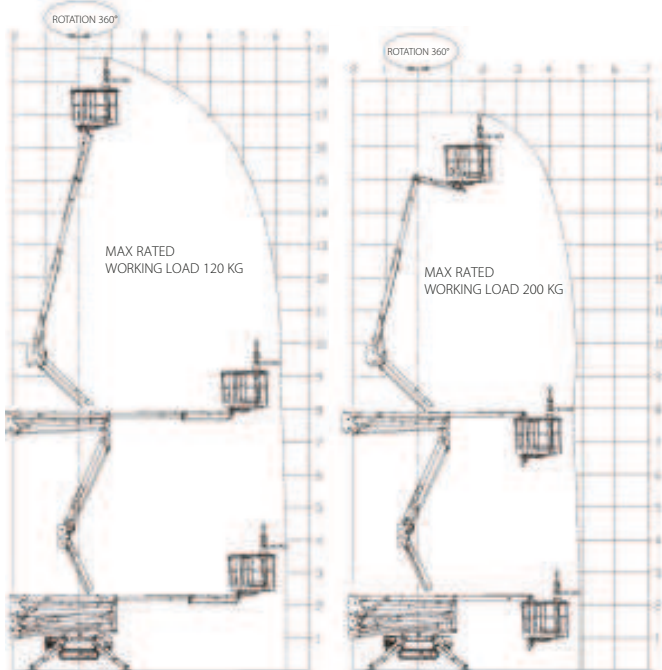

Dimensions

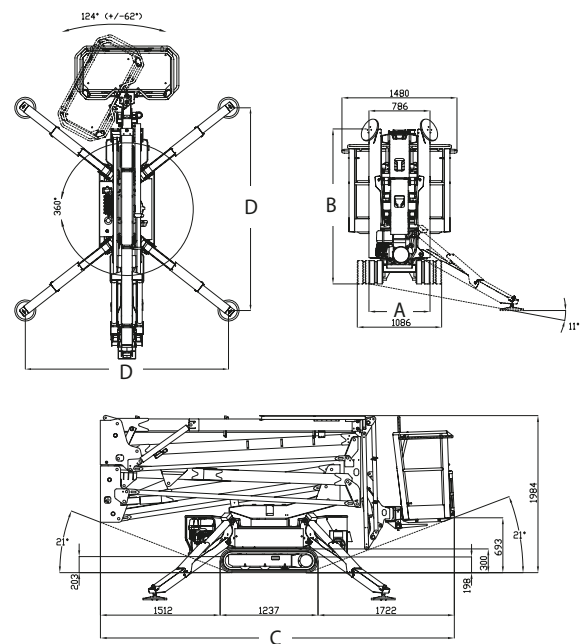

IMPORTANT

JLG is continually researching and developing products and reserves the right to make modifications without prior notice. All data in this document is indicative. Certain options or country standards will increase weight. Specifications may change to meet country standards or with the addition of optional equipment.

Due to continuous product improvements, JLG Industries reserves the right to make specification and/or equipment changes without prior notification.



JLG EMEA BV

Polaris Avenue 63
2132 JH Hoofddorp
The Netherlands
Tel: +31 (0)23 565 5665
Fax: +31 (0)23 557 3750
www.jlg.com

An Oshkosh Corporation Company